

THE INFORMATION CONTAINED IN THIS DRAWING IS THE SOLE PROPERTY OF SUNCOR STAINLESS. ANY REPRODUCTION IN PART OR WHOLE WITHOUT THE WRITTEN PERMISSION OF SUNCOR STAINLESS IS PROHIBITED.

REVISIONS			
REV	DESCRIPTION	DATE	APPROVED
A	SAMPLE DRAWING	X-X-XX	

Deck or mounting area and stair dimensions **MUST** be confirmed by the customer and or contractor. It shall be the customer's responsibility to review the drawing(s) for accuracy.

Suncor/Atlantis Rail Systems will **NOT** be responsible for errors or misinterpretations of the railing system designed by us based upon customer confirmed dimensions.

Additional drawing time to change the design or correct for errors after signing will result in additional costs as well as any changes to parts made per the drawing.

Carefully review the drawing before signing and accepting. By signing and accepting the customer acknowledges the drawing and it's representation of the railing system, including but **NOT** limited to layout, dimensions, heights, **NOTES** and mounting, is accurate.

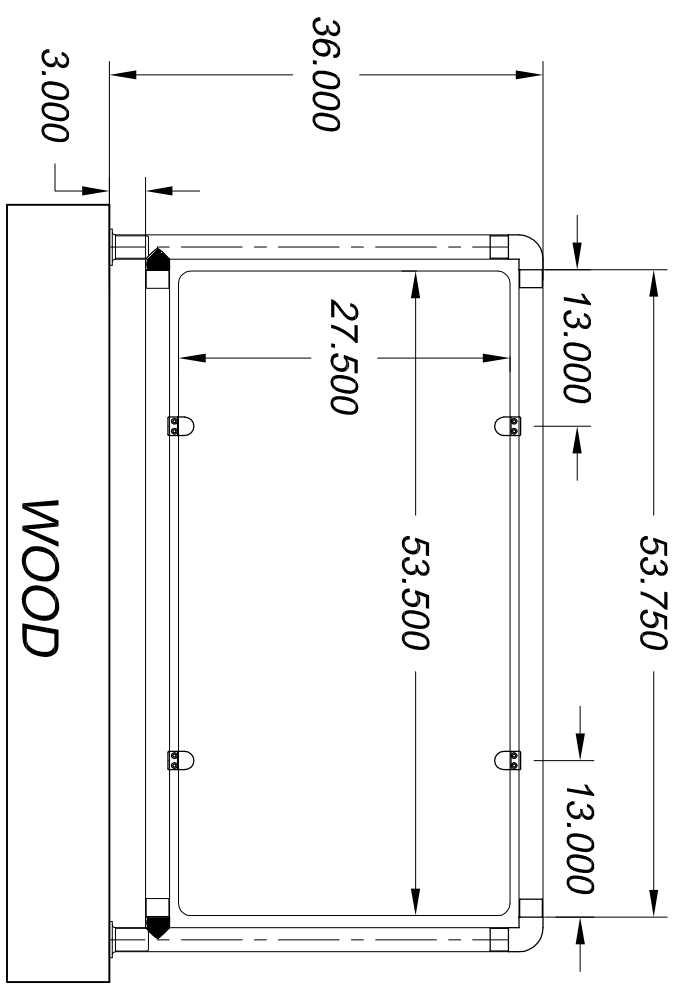
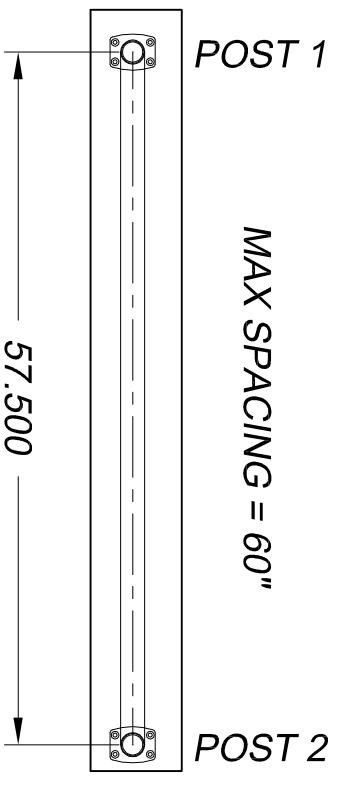

- NOTES:
1. 36" HAND RAIL SYSTEM CONSISTING OF NAUTILUS STYLE WITH GLASS INFILL.
 2. DRAWING AND DIMENSIONS BASED UPON CUSTOMER SUPPLIED DRAWINGS AND INFORMATION. CUSTOMER SHALL VERIFY FOR ACCURACY.
 3. ALL DIMENSIONS AND RAILING DETAILS ARE PENDING CUSTOMER APPROVAL.
 4. 36" RALEASY HAND RAIL SYSTEM CONSISTING OF 2" DIA POLISHED 16 GAUGE 316 SS TUBING, CAST 316 SS FITTINGS, EPOXY CONNECTIONS AT JOINTS.
 5. GLASS INFILL IS NOT PROVIDED.

CUSTOMER SIGNATURE: _____ DATE: _____

FINISH		POLISHED	
MATERIAL		316SS	
CHECKED		DATE	
APPROVALS		DATE	
DESIGNED		DATE	
DRAWN		DATE	
SCALE		1" = 1'-0"	
SHEET		1 OF 1	



SAMPLE DRAWING
36" SUNRAIL GLASS

SIZE	FSM NO.	ORDER NO.	REV
D		XXXXXX-XX	A
SCALE	DATE	SHEET	
1" = 1'-0"		1 OF 1	

8 7 6 5 4 3 2 1

A B C D

POSTS SHOWN AS MOUNTED ON WOOD.