

THE INFORMATION CONTAINED IN THIS DRAWING IS THE SOLE PROPERTY OF SUNCOR STAINLESS. ANY REPRODUCTION IN PART OR WHOLE WITHOUT THE WRITTEN PERMISSION OF SUNCOR STAINLESS IS PROHIBITED.

REVISIONS			
REV	DESCRIPTION	DATE	APPROVED
A	SAMPLE DRAWING	XX/X/XX	XXX

Deck or mounting area and stair dimensions **MUST** be confirmed by the customer and or contractor. It shall be the customer's responsibility to review the drawing(s) for accuracy.

Suncor/Atlantis Rail Systems will **NOT** be responsible for errors or misinterpretations of the railing system designed by us based upon customer confirmed dimensions.

Additional drawing time to change the design or correct for errors after signing will result in additional costs as well as any changes to parts made per the drawing.

Carefully review the drawing before signing and accepting. By signing and accepting the customer acknowledges the drawing and it's representation of the railing system, including but **NOT** limited to layout, dimensions, heights, **NOTES** and mounting, is accurate.

- NOTES:
- HAND RAIL SYSTEM CONSISTING OF LATITUDE STYLE WITH HORIZONTAL WIRE ROPE.
 - DRAWING AND DIMENSIONS BASED UPON CUSTOMER SUPPLIED DRAWINGS
 - ALL DIMENSIONS AND RAILING DETAILS ARE PENDING CUSTOMER APPROVAL
 - 36" HAND RAIL SYSTEM CONSISTING OF 2" DIA ELECTRO-POLISHED 16 GAUGE 316 SS TUBING, CAST 316 SS FITTINGS, EPOXY CONNECTIONS AT JOINTS
 - DO NOT TENSION THE TENSIONERS UNTIL THE CUSTOMER SUPPLIED UPPER HAND RAIL IS INSTALLED.
 - ALL POSTS SHOWN AS MOUNTED TO WOOD.

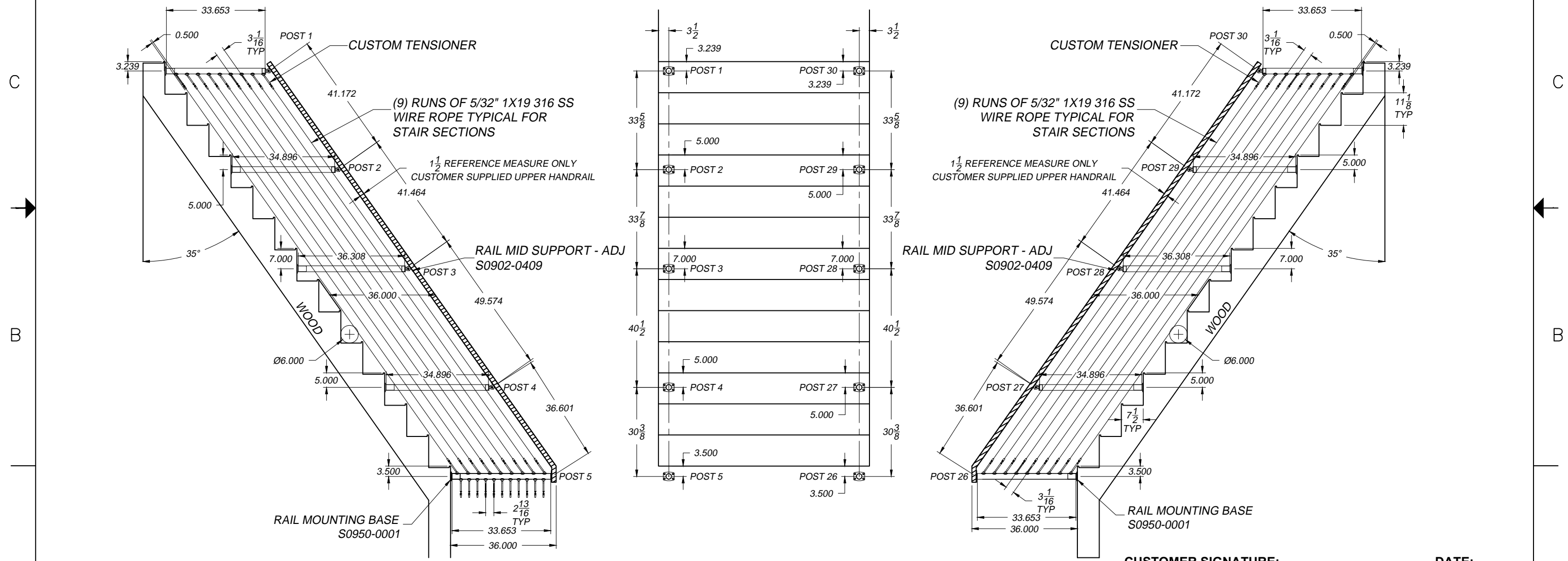

**STAIR DETAIL A - PROJECTION VIEW
NTS**

UNLESS OTHERWISE SPECIFIED DIMENSIONS ARE IN INCHES TOLERANCES ARE:		CAD GENERATED DRAWING DO NOT MANUALLY UPDATE	
FRACTIONS	DECIMALS	ANGLES	
±1/64"	±0.005	±1/2	
XX	±0.001	XXX	±0.005
DRAWN: XXX		DATE: XX/XX/XX	
MATERIAL:	CHECKED:	RESP ENG:	
316SS			
FINISH:		MFG ENG:	
ELECTRO-POLISHED			
		QUAL ENG:	

CUSTOMER SIGNATURE: _____ **DATE:** _____

**ATLANTIS
RAIL SYSTEMS**

LATITUDE CABLE RAILING - STAIR
SAMPLE DRAWING

SIZE: D	FSCM NO.:	ORDER NO.:	REV: A
		XXXXXX-XX	
SCALE: NTS		CAD FILE: xxxxxxxxxxxx	SHEET 1 OF 1